

# Quantum Electromagnetics: A New Look—Part I

W. C. Chew, A. Y. Liu, C. Salazar-Lazaro, and W. E. I. Sha

(Invited Paper)

**Abstract**—Quantization of the electromagnetic field has been a fascinating and important subject since its inception. This subject topic will be discussed in its simplest terms so that it can be easily understood by a larger community of researchers. A new way of motivating Hamiltonian mechanics is presented together with a novel way of deriving the quantum equations of motion for electromagnetics. All equations of motion here are derived using the generalized Lorenz gauge with vector and scalar potential formulation. It is well known that the vector potential manifests itself in the Aharonov–Bohm effect. By advocating this formulation, it is expected that more quantum effects can be easily incorporated in electromagnetic calculations. Using a similar approach, the quantization of electromagnetic fields in reciprocal, anisotropic, inhomogeneous media is presented. Finally, the Green’s function technique is described when the quantum system is linear time invariant. These quantum equations of motion for Maxwell’s equations portend well for a better understanding of quantum effects in many technologies.

**Index Terms**—Anisotropic inhomogeneous media, Maxwell’s equations, quantum mechanics, vector and scalar potentials.

## I. INTRODUCTION

ELECTROMAGNETIC theory as completed by Maxwell in 1865 [1] is just over 150 years old now. Putatively, the equations were difficult to understand [2]; distillation and cleaning of the equations were done by Oliver Heaviside and Heinrich Hertz [3]; experimental confirmations of these equations were not done until some 20 years later in 1888 by Hertz [4].

As is the case with the emergence of new knowledge, it is often confusing at times, and inaccessible to many. Numerous developments of electromagnetic theory have ensued since Maxwell’s time; we shall discuss them in the next section. In this paper, we will reinterpret this relatively new body of knowledge on quantum electromagnetics (or quantum effects in electromagnetics, or quantization of electromagnetic fields) so as to render it more accessible to a larger community, and thereby popularizing this important field. This name is appropriate as it is expected that these effects will be felt across the electromagnetic spectrum in addition to optics. The rise of the importance of quantum electromagnetics is spurred by technologies for single-photon sources and measurements [5], [6], the validation of Bell’s theorem [7], and the leaps and bounds progress in nanofabrication technologies.

Manuscript received April 27, 2016; revised July 26, 2016; accepted August 30, 2016. Date of publication October 12, 2016; date of current version November 1, 2016.

W. C. Chew, A. Y. Liu, and C. Salazar-Lazaro are with the Department of Electrical and Computer Engineering, University of Illinois at Urbana–Champaign, Champaign, IL 61801 USA (e-mail: w-chew@uiuc.edu; liu141@illinois.edu; slzrlzr2@illinois.edu).

W. E. I. Sha is with the Department of Electrical and Electronics Engineering, The University of Hong Kong, Hong Kong (e-mail: shawei@hku.hk).

Digital Object Identifier 10.1109/JMMCT.2016.2617018

The validation of Bell’s theorem in favor of the Copenhagen school of interpretation opens up new possibilities for quantum information, computing, cryptography, and communication [8]. Nanofabrication techniques further allow the construction of artificial atoms such as quantum dots that are microscopic in scale. Moreover, potentials for using such artificial atoms to manipulate quantum information abound. In this case, semiclassical calculations where the fields are treated classically and the atom treated quantum mechanically [9], [10] do not suffice to support many of the emerging technologies, when the number of photons is limited, such as single-photon-based devices and high-sensitivity photodetectors. Another interesting example is the circuit quantum electrodynamics (QED) at microwave frequencies where a superconducting-quantum-interference-device-based artificial atom is entangled with coplanar waveguide microwave resonators [11]. For these situations, fully quantum field–artificial-atom calculations need to be undertaken [12].

The recent progress in nanofabrication technology underscores the importance of quantum effects at nanoscale, first on electron transport [13] and now on the importance of photon–artificial-atom interaction at nanoscale. Moreover, nanofabrication emphasizes the importance of photons and the accompanying quantum effects in heat transfer. While phonons require material media for heat transfer, photons can account for near-field heat transfer through vacuum, where classical heat conduction equation and Kirchhoff’s law of thermal radiation are invalid. Furthermore, the confirmation of Casimir force in 1997 [14] revives itself as an interesting research topic. Several experiments confirmed that Casimir force is, in fact, real and entirely quantum in origin: it can be only explained by using the quantum theory of electromagnetic field in its quantized form [15], [16]. Also, Casimir force cannot be explained by classic electromagnetics theory that assumes null electromagnetic field in vacuum.

More importantly, the use of the ubiquitous Green’s function is still present in many quantum calculations [17]–[19]. Hence, the knowledge and effort in computational electromagnetics (CEM) for computing Green’s functions of complicated systems have not gone obsolete or in vain [20]–[23]. Therefore, the development of CEM, which has been important for decades for the development of many classical electromagnetics technologies all across the electromagnetic spectrum, will be equally important in the development of quantum technologies. The beginning of this paper is mainly pedagogical in order to make this knowledge more accessible to the general electromagnetics community. Hopefully with this paper, a bridge can be built between the electromagnetics community and the physics community to foster cross pollination and collaborative research for new knowledge discovery. The novelty in this

paper is the presentation of a simplified derivation for classical Hamilton equations, as well as quantum Hamilton equations (47) with striking similarities to their classical counterparts. The process of quantization of scalar potential, vector potential, and electromagnetic fields is also novel.

In Part I of this work, a novel way to quantize electromagnetic fields in the coordinate  $(\mathbf{r}, t)$  space will be presented. This allows the derivation of the quantum equations of motion for scalar and vector potentials, as well as electromagnetic fields.

## II. IMPORTANCE OF ELECTROMAGNETIC THEORY

Since the advent of Maxwell's equations in 1865, the enduring legacy of these equations have been pervasive in many fields. As aforementioned, it was not until 1888 that Hertz [4] experimentally demonstrated that remote induction effect was possible. And in 1893, Tesla [24] demonstrated the possibility of radio; in 1897, Marconi [25] demonstrated wireless transmission, followed by transatlantic transmission in 1901. Maxwell did not know the importance of the equations that he had completed. Many advanced understanding of electromagnetic theory in its modern form did not emerge until many years after his death: It will be interesting to recount these facts.

- 1) Since Maxwell's equations unify the theories of electromagnetism and optics, it is valid over a vast length scale. Electromagnetic theory is valid for subatomic particle interaction, as well as being responsible for the propagation of light wave and radio wave across the galaxies.
- 2) With the theory of special relativity developed by Einstein in 1905 [26], these equations were known to be relativistically invariant. In other words, Maxwell's equations remain the same in a spaceship irrespective of how fast it is moving. Electrostatic theory in one spaceship becomes electrodynamic theory in a moving spaceship relative to the first one.
- 3) The development of QED by Dirac in 1927 [27] indicates that Maxwell's equations are valid in the quantum regime as well. Initially, QED was studied by Dyson, Feynman, Schwinger, and Tomonaga, mainly to understand the interparticle interactions in the context of quantum field theory to determine fine structure constants and their anomalies due to quantum electromagnetic fluctuations [28]. However, the recent rise of quantum information has spurred QED's application in optics giving rise to the field of quantum optics [29]–[35].
- 4) Later, with the development of differential forms by Cartan in 1945 [36], [37], it is found that electromagnetic theory is intimately related to differential geometry. Electromagnetic theory inspired Yang–Mills theory, which was developed in 1954 [38], [39]; it is regarded as a generalized electromagnetic theory. In fact, as quoted by Misner *et al.*, it is said that “Differential forms illuminate electromagnetic theory, and electromagnetic theory illuminates differential forms” [40], [41].
- 5) In 1985, Feynman wrote that QED (a superset of electromagnetic theory) had been validated to be one of the most accurate equations to a few parts in a billion [42]. This is equivalent to an error of a few human hair

widths compared to the distance from New York to Los Angeles. More recently, Styer wrote in 2012 [43] that the accuracy had been improved to a few parts in a trillion [44]: such an error is equivalent to a few human hair widths in the distance from the Earth to the Moon.

- 6) More importantly, since Maxwell's equations have been around for over 150 years, they have pervasively influenced the development of a large number of scientific technologies. This impact is particularly profound in electrical engineering, ranging from rotating machinery, oil-gas exploration, magnetic resonance imaging, to optics, wireless and optical communications, computers, remote sensing, bioelectromagnetics, etc.

Despite the cleaning up of Maxwell's equations by Oliver Heaviside, he has great admiration for Maxwell as seen from his following statement [3], “*A part of us lives after us, diffused through all humanity—more or less—and through all nature. This is the immortality of the soul. There are large souls and small souls. The immoral soul of the “Scientificists” is a small affair, scarcely visible. Indeed its existence has been doubted. That of a Shakespeare or Newton is stupendously big. Such men live the bigger part of their lives after they are dead. Maxwell is one of these men. His soul will live and grow for long to come, and hundreds of years hence will shine as one of the bright stars of the past, whose light takes ages to reach us.*”

## III. LONE SIMPLE HARMONIC OSCILLATOR

Electromagnetic fields and waves can be thought of as a consequence of the coupling of simple harmonic oscillators. Hence, it is prudent first to study the physics of a lone harmonic oscillator, followed by analyzing a set of coupled harmonic oscillators. A lone harmonic oscillator can be formed by two masses connected by a spring, two molecules connected to each other by molecular forces, an electron trapped in a parabolic potential well, an electrical  $LC$  tank circuit, or even an electron–positron (e-p) pair bound to each other. The simplest description of the harmonic oscillator is via classical physics and Newton's law. The inertial force of a mass is given by mass times acceleration, while the restoring force of the mass can be described by Hooke's law. Hence, the equation of motion of a classical simple harmonic oscillator is

$$m \frac{d^2}{dt^2} q(t) = -\kappa q(t) \quad (1)$$

where  $m$  is the mass of the particle,  $q$  denotes the position of the particle,<sup>1</sup> and  $\kappa$  is the spring constant. In the above,  $\frac{d^2}{dt^2} q(t)$  is the acceleration of the particle. The general solution to the above is

$$q(t) = b_1 \cos(\Omega t) + b_2 \sin(\Omega t) = b \cos(\Omega t + \theta) \quad (2)$$

where  $\Omega = \sqrt{\kappa/m}$  is the resonant frequency of the oscillator, and  $b$  and  $\theta$  are arbitrary constants. It has only one characteristic resonant frequency. The momentum is defined as  $p(t) = m \frac{d}{dt} q(t)$  and, hence, is

$$\begin{aligned} p(t) &= -m\Omega b_1 \sin(\Omega t) + m\Omega b_2 \cos(\Omega t) \\ &= -m\Omega b \sin(\Omega t + \theta). \end{aligned} \quad (3)$$

<sup>1</sup> $q$  is used to denote position here, as  $x$  is reserved for later use.

#### IV. LONE QUANTUM SIMPLE HARMONIC OSCILLATOR

In the microscopic regime, a simple harmonic oscillator displays quantum phenomena [8], [9], [48]–[53], [55]. Hence, the classical picture of the state of the particle being described by its position  $q$  and momentum  $p$  is insufficient. Therefore, in quantum mechanics, the state of the particle has to be more richly endowed by a wave function  $\psi(q, t)$ . The motion of the wave function is then governed by the Schrödinger equation.

Quantum mechanics cannot be derived: it was postulated, and the corresponding equation postulated by Schrödinger is [56]

$$\left(-\frac{\hbar^2}{2m} \frac{\partial^2}{\partial q^2} + V(q)\right) \psi(q, t) = i\hbar \frac{\partial}{\partial t} \psi(q, t) \quad (4)$$

where  $V(q) = \frac{1}{2}m\Omega^2 q^2$  for the harmonic oscillator. The above is a parabolic wave equation (for a classification of equations, see [23, p. 527]) describing the trapping of a wave function (or a particle) by a parabolic potential well of the harmonic oscillator. The state of the particle is described by the wave function  $\psi(q, t)$ . Once the wave function is obtained by solving the above partial differential equation, then the position of the particle is obtain by

$$\langle q(t) \rangle = \int_{-\infty}^{\infty} dq |\psi(q, t)|^2 q = \langle \psi | q | \psi \rangle \quad (5)$$

where the angular brackets have been used to denote the expectation value of a random variable as in probability. The last equality follows from the use of Dirac notation [27] (also see Appendix in Part II). The wave function is normalized such that

$$\int_{-\infty}^{\infty} dq |\psi(q, t)|^2 = 1. \quad (6)$$

Therefore,  $|\psi(q, t)|^2 = P(q, t)$  can be thought of as a probability distribution function for the random variable  $q$ . And (5) can be thought of as the expectation value of  $q$ , which is time varying because the wave function  $\psi(q, t)$  is time varying.

The above is the recipe for determining the motion of a particle in quantum mechanics and is an important attribute of the probabilistic interpretation of quantum mechanics. Furthermore, the quantum interpretation implies that the position of the particle is indeterminate until after a measurement is made (see [8] for more discussion on quantum interpretation). Furthermore, the probabilistic interpretation implies that the position  $q$  and momentum  $p$  are not deterministic quantities. They have a spread or standard deviation commensurate with their probabilistic description. This spread is known as the Heisenberg uncertainty principle [8], [9].

To simplify the solution of the Schrödinger equation, one can first solve for its eigenmodes or assumes that the modal solution is time harmonic such that

$$i\hbar \frac{\partial}{\partial t} \psi_n(q, t) = E_n \psi_n(q, t). \quad (7)$$

In other words, by the separation of variables

$$\psi_n(q, t) = \psi_n(q) e^{-i\omega_n t} \quad (8)$$

such that  $\hbar\omega_n = E_n$ ; the eigenvalues have to be real for energy conservation or probability density conservation. Then, (4)

can be converted to a time-independent ordinary differential equation

$$\left(-\frac{\hbar^2}{2m} \frac{d^2}{dq^2} + \frac{1}{2}m\Omega^2 q^2\right) \psi_n(q) = E_n \psi_n(q) \quad (9)$$

where  $E_n$  is its eigenvalue. These time-independent solutions are known as stationary states because  $|\psi_n(q, t)|^2 = P_n(q, t) = |\psi_n(q)|^2$  is time independent. The above equation has infinitely many closed-form eigensolutions dealt with more richly in many text books (e.g., in [29]–[35]). It is important to note that the eigenvalues are given by

$$E_n = \hbar\Omega \left(n + \frac{1}{2}\right) = \hbar\omega_n \quad (10)$$

with

$$\omega_n = \Omega \left(n + \frac{1}{2}\right). \quad (11)$$

It is to be noted that  $\Omega$  is the natural resonant frequency of the harmonic oscillator, whereas  $\omega_n$  is the frequency of the stationary state. Hence, in quantum theory, the harmonic oscillator can assume only discrete energy levels,  $E_n$ , and its energy can only change by discrete amount of  $\hbar\Omega$ . This quantum of energy  $\hbar\Omega$  is ascribed to that of a single photon. For instance, a quantum harmonic oscillator can change its energy level by absorbing energy from its environment populated with photons, each carrying a packet of energy of  $\hbar\Omega$ , or conversely, by the emission of a photon. Even when  $n = 0$ , implying the absence of photons (or zero field in the classical sense),  $E_n$  is not zero, giving rise to a fluctuating field which is the vacuum fluctuation of the field. Since this topic is extensively discussed in many text books [29]–[35], it will not be elaborated here.

#### A. Hamiltonian Mechanics Made Simple

Since quantum mechanics is motivated by Hamiltonian mechanics, the classical Hamiltonian mechanics will be first reviewed. This mechanics is introduced in most textbooks by first introducing Lagrangian mechanics. Then, the Hamiltonian is derived from the Lagrangian by a Legendre transform [45]. In this paper, a simple way to arrive at the Hamilton equations of motion will be given.

The Hamiltonian represents the total energy of the system, expressed in terms of the momentum  $p$  and the position  $q$  of a particle. For the lone harmonic oscillator, this Hamiltonian is given by

$$H = T + V = \frac{p^2(t)}{2m} + \frac{1}{2}\kappa q^2(t). \quad (12)$$

Here,  $p(t) = m \frac{d}{dt} q(t)$  is the momentum of the particle. The first term,  $T = \frac{p^2(t)}{2m}$ , represents the kinetic energy of the particle, while the second term,  $V = \frac{1}{2}\kappa q^2(t)$ , is the potential energy of the particle: it is the energy stored in the spring as expressed by Hooke's law. In the above,  $p(t)$  and  $q(t)$  are independent variables. The Hamiltonian, representing total energy, is a constant of motion for an energy-conserving system, viz., the total energy of such a system cannot vary with time. Hence,  $p(t)$  and  $q(t)$  should vary with time  $t$  to reflect energy conservation.



Taking the first variation of the Hamiltonian with respect to time leads to

$$\delta H = \frac{\partial H}{\partial p} \frac{\partial p}{\partial t} \delta t + \frac{\partial H}{\partial q} \frac{\partial q}{\partial t} \delta t = 0. \quad (13)$$

In order for  $\delta H$  to be zero, one possibility is that

$$\frac{\partial q}{\partial t} = \frac{\partial H}{\partial p} \quad \frac{\partial p}{\partial t} = -\frac{\partial H}{\partial q}. \quad (14)$$

The above equations are the Hamilton equations of motion.<sup>2</sup> But the above equations are only determined to within a multiplicative constant, as  $\delta H$  is still zero when we multiply the right-hand side of both equations by a constant. This ambiguity follows from that a Hamiltonian which is multiplied by a constant is still a constant of motion. However, the constant can be chosen so that Newtonian mechanics is reproduced.

Applying the Hamilton equations of motion yields

$$\frac{\partial q}{\partial t} = \frac{p}{m} \quad \frac{\partial p}{\partial t} = -\kappa q. \quad (15)$$

The above can be combined to yield (1). These equations of motion imply that if  $p$  and  $q$  are known at a given time, then time-stepping the above equations in the manner of the finite-difference time-domain method [46], [47], their values at a later time can be obtained.

The momentum and position can be normalized to yield a Hamiltonian of the form

$$H = \frac{1}{2} [P^2(t) + Q^2(t)] \quad (16)$$

where  $P(t) = p(t)/\sqrt{m}$ , and  $Q(t) = \sqrt{\kappa}q(t)$ . With the use of (2) and (3), it can be shown that kinetic and potential energies are time varying, but the sum of them is a constant implying energy conservation.

An alternative representation is to factorize the above into

$$\begin{aligned} H &= \frac{1}{2} [P^2(t) + Q^2(t)] \\ &= \frac{1}{2} [iP(t) + Q(t)] [-iP(t) + Q(t)] \\ &= B(t)B^*(t) = \frac{1}{2} (B(t)B^*(t) + B^*(t)B(t)) \end{aligned} \quad (17)$$

where  $B(t) = iP(t) + Q(t)$ . If  $P(t)$  and  $Q(t)$  represent sinusoidal functions in quadrature phase, as seen in (2) and (3), then  $B(t)$  is now a complex rotating wave with a time dependence of  $e^{-i\Omega t}$ . Clearly,  $B(t)B^*(t)$  is independent of time, indicating that the Hamiltonian is a constant of motion.

## V. SCHRÖDINGER EQUATION IN OPERATOR NOTATION

The Schrödinger equation in (4) can be formally written as [9], [55]

$$\hat{H}|\psi\rangle = i\hbar\partial_t|\psi\rangle \quad (18)$$

where  $\hat{H}$  is an operator in the Hilbert space (an infinite-dimensional vector space where the vectors have finite energy

or norm, and the matrix operators that act on these vectors are also infinite dimensional). Here,  $|\psi\rangle$  is a vector in Hilbert space that  $\hat{H}$  acts on. Furthermore,

$$\hat{H} = \hat{T} + \hat{V} \quad (19)$$

where  $\hat{T}$  is the kinetic energy operator, while  $\hat{V}$  is the potential energy operator. In order to conserve energy, the Hamilton operator  $\hat{H}$  and the operators  $\hat{T}$  and  $\hat{V}$  have to be Hermitian so that their eigenvalues are real. The eigenvalues of  $\hat{H}$  have to be real so that  $E_n$  in the previous section is real for energy conservation.

For a general Schrödinger equation

$$\hat{T} = \frac{\hat{p}^2}{2m} \quad \hat{V} = V(\hat{q}). \quad (20)$$

To find the coordinate matrix representation of the above operator equation, one first defines a set of orthonormal vectors with the property that their inner product is

$$\langle q|q'\rangle = \delta(q - q'). \quad (21)$$

Furthermore,  $\langle q|\psi\rangle = \psi(q)$ , namely, that the conjugate transpose vector  $\langle q|$  has the sifting property that its inner product with the vector  $|\psi\rangle$  yields a number that represents the value of the function  $\psi$  in the coordinate location  $q$ . One further uses the definition of an identity operator [9], [55] (see also Appendix B in Part II)

$$\hat{I} = \int dq|q\rangle\langle q| \quad (22)$$

where  $|q\rangle$  is a set of orthonormal vectors. The above is a rather sloppy notation because  $q$  is used as an index of the vector  $|q\rangle$  as well as a position variable. And by the same token,  $|q\rangle\langle q|$  is an outer product of two vectors.

By inserting the identity operator between  $\hat{H}$  and  $|\psi\rangle$  in (18), and testing the resulting equation with  $\langle q'|$ , (18) becomes

$$\int dq\langle q'|\hat{H}|q\rangle\langle q|\psi\rangle = i\hbar\partial_t\langle q'|\psi\rangle. \quad (23)$$

Consequently, the coordinate matrix representation [9], [55], [23, p. 281] (see Appendix B of Part II) of the Hamiltonian operator is

$$\langle q'|\hat{H}|q\rangle = \langle q'|\hat{T}|q\rangle + \langle q'|\hat{V}|q\rangle. \quad (24)$$

Here, one assumes that the vector  $|q\rangle$ , indexed by the variable  $q$ , forms a complete orthonormal set, and the matrix representation is the projection of the operator into the space spanned by the set of vectors  $|q\rangle$ .

The coordinate matrix representations of these operators are (more discussions will be found in the Appendix in Part II)

$$\langle q'|\hat{T}|q\rangle = -\frac{\hbar^2}{2m} \frac{\partial^2}{\partial q^2} \delta(q - q') \quad \langle q'|\hat{V}|q\rangle = \delta(q - q')V(q). \quad (25)$$

They are distribution functions, but they are often sloppily written as

$$\hat{T} = -\frac{\hbar^2}{2m} \frac{\partial^2}{\partial q^2} \quad \hat{V} = V(q). \quad (26)$$

<sup>2</sup>We could have used total derivatives for  $\frac{\partial q}{\partial t}$  and  $\frac{\partial p}{\partial t}$ , but these conjugate variables will later become functions of space as well as time.

These are often sloppily called the coordinate representations of these operators.

If such representations of these operators are assumed, and identify that  $\psi(q) = \langle q|\psi\rangle$ , by inserting (25) into (23), then the equation postulated by Schrödinger in (4) is obtained. For a quantum harmonic oscillator,  $\hat{V} = \frac{1}{2}m\Omega^2\hat{q}^2$ . In general,

$$\hat{V} = V(\hat{q}) \quad (27)$$

where  $\hat{q}$  is the position operator. In the above, a function of an operator has meaning only when it is written as a power series or a Taylor expansion and then acts on an eigenvector of the position operator  $\hat{q}$ . For instance,  $f(\hat{q})$  has meaning only if it acts on an eigenvector of  $\hat{q}$ , namely,  $|q\rangle$ . On that account

$$\hat{q}|q\rangle = q|q\rangle \quad \hat{q}^n|q\rangle = q^n|q\rangle$$

or that

$$\begin{aligned} f(\hat{q})|q\rangle &= [a_0 + a_1\hat{q} + a_2\hat{q}^2 + a_3\hat{q}^3 + \dots]|q\rangle \\ &= (a_0 + a_1q + a_2q^2 + a_3q^3 + \dots)|q\rangle \\ &= f(q)|q\rangle = |q\rangle f(q) \end{aligned}$$

Then

$$V(\hat{q})|q\rangle = V(q)|q\rangle. \quad (28)$$

It is clear from the above that functions of operators are themselves operators.

The postulate for Schrödinger is also motivated by earlier proposition by de Broglie [57] that the momentum of a particle is given by

$$p = \hbar k = \hbar \frac{2\pi}{\lambda}. \quad (29)$$

Hence, for a plane wave function  $\psi(q)$  with  $\exp(ikq)$  dependence representing the state of the particle, the momentum is expressible as

$$pe^{ikq} = \hbar k e^{ikq} = -i\hbar\partial_q e^{ikq} = -i\hbar\partial_q \psi(q). \quad (30)$$

Therefore, the momentum operator in coordinate representation is

$$\hat{p} = -i\hbar \frac{\partial}{\partial q} = -i\hbar\partial_q. \quad (31)$$

But the general momentum operator  $\hat{p}$  should be more appropriately written as

$$\hat{p} = -i\hbar \frac{\partial}{\partial \hat{q}} = -i\hbar\partial_{\hat{q}}. \quad (32)$$

The above derivative with respect to an operator has meaning only if it acts on a vector that is a function of the operator  $\hat{q}$ . Such a vector can be constructed by  $|\psi_1\rangle = f(\hat{q})|\psi\rangle$ . We can expand  $|\psi\rangle$  in terms of the orthonormal basis  $|q\rangle$  or simply let  $|\psi\rangle = |q\rangle$ , since the operator  $f(\hat{q})$  has meaning only if it acts on the eigenvector of the operator  $\hat{q}$ , namely,  $\partial_{\hat{q}}f(\hat{q})|q\rangle = \partial_q f(q)|q\rangle = |q\rangle\partial_q f(q)$ . As a final note, the Schrödinger equation was also motivated by the findings of Planck [58] and the photoelectric effect [59], [60], which suggest that  $E = \hbar\Omega$ , where  $E$  is the energy of a photon.

## VI. SCHRÖDINGER PICTURE VERSUS HEISENBERG PICTURE

At this juncture, it is prudent to discuss the difference between the Schrödinger picture versus the Heisenberg picture of quantum mechanics [9], [48], [49], [51], [52]. In the Schrödinger picture, the time dependence is in the wavefunction or the state vector  $|\psi\rangle = |\psi(t)\rangle$ , whereas in the Heisenberg picture, the time dependence is in the operator that represents an observable, which is a measurable quantity. As shall be seen, the Heisenberg picture is closer to the classical picture.

The formal solution to the Schrödinger equation (18) in operator form can be written as

$$|\psi(t)\rangle = e^{-\frac{i}{\hbar}\hat{H}t}|\psi_0\rangle \quad (33)$$

where  $|\psi_0\rangle = |\psi(0)\rangle$  is the state vector at  $t = 0$ , which is independent of time, and  $\hat{H}$  in (19) is time independent. The expectation value of an operator  $\hat{O}$ , which represents an observable or a measurable quantity, is

$$\begin{aligned} \langle\hat{O}\rangle &= \langle\psi(t)|\hat{O}|\psi(t)\rangle \\ &= \langle\psi_0|e^{\frac{i}{\hbar}\hat{H}t}\hat{O}e^{-\frac{i}{\hbar}\hat{H}t}|\psi_0\rangle \\ &= \langle\psi_0|\hat{O}_H(t)|\psi_0\rangle. \end{aligned} \quad (34)$$

In the above,  $\hat{O}$  is time independent in the Schrödinger picture, but  $\hat{O}_H(t)$  is time dependent in the Heisenberg picture. Hence, in general, the relationship between an operator in the Schrödinger picture and in the Heisenberg picture is given by

$$\hat{O}_H(t) = e^{\frac{i}{\hbar}\hat{H}t}\hat{O}_S e^{-\frac{i}{\hbar}\hat{H}t} \quad (35)$$

where the subscripts “ $H$ ” and “ $S$ ” mean the Heisenberg picture and the Schrödinger picture, respectively. Clearly,  $\hat{O}_S = \hat{O}_H(t = 0)$ . It can be shown easily that

$$\frac{d\hat{O}_H}{dt} = \frac{i}{\hbar} \left( \hat{H}\hat{O}_H - \hat{O}_H\hat{H} \right) = \frac{i}{\hbar} [\hat{H}, \hat{O}_H] \quad (36)$$

where  $[\hat{H}, \hat{O}_H] = \hat{H}\hat{O}_H - \hat{O}_H\hat{H}$  is a commutator as defined by the above equation. This is the Heisenberg equation of motion for quantum operators. The commutator plays an important role in quantum mechanics: when two operators do not commute, or that their commutator is nonzero, then they cannot be determined precisely simultaneously. More discussions can be found in standard quantum mechanics books [9], [55].

### A. Quantum Hamiltonian Mechanics

We can derive the quantum version of Hamiltonian mechanics. In the Heisenberg picture, the operators that represent observables are functions of time, and the equations of motion for the observable operators in Heisenberg picture evolve as

$$\frac{\partial\hat{q}}{\partial t} = -\frac{i}{\hbar} [\hat{q}, \hat{H}] \quad \frac{\partial\hat{p}}{\partial t} = -\frac{i}{\hbar} [\hat{p}, \hat{H}]. \quad (37)$$

The basic commutation relation is

$$[\hat{q}, \hat{p}] = \hat{q}\hat{p} - \hat{p}\hat{q} = i\hbar\hat{I}. \quad (38)$$

Equation (38) above can be easily verified in the Schrödinger picture because the coordinate representations of  $\hat{p}$  and  $\hat{q}$  are

$$\hat{p} = -i\hbar\partial_q = -i\hbar \frac{\partial}{\partial q} \quad \hat{q} = q. \quad (39)$$

Hence, (38) can be easily verified by substituting the above into it. In other words, they follow from de Broglie and Schrödinger postulates, which are the fundamental postulates leading to quantum mechanics. In contrast, some schools assume that the commutation relation  $[\hat{q}, \hat{p}] = i\hbar\hat{I}$  as the fundamental quantum postulate, and that de Broglie and Schrödinger postulates being derivable from it [8], [53]. Some authors refer to this as canonical quantization, where the classical variables  $p$  and  $q$  as canonical variables that are elevated to be quantum operators, and the commutation relation between them as canonical commutation [52]. The two views are largely equivalent, but we favor the historical development over the formal commutation relation.

Having verified (38) in the Schrödinger picture, it can be easily verified in the Heisenberg picture as well, namely,

$$[\hat{q}(t), \hat{p}(t)] = i\hbar\hat{I}. \quad (40)$$

The above is also known as the equal time commutator.

It can be shown by the repeated application of the commutator in (38) that [52]

$$[\hat{p}, \hat{q}^n] = -in\hat{q}^{n-1}\hbar. \quad (41)$$

Note that the above is derived without applying calculus, but only using (40). Nevertheless, we can borrow the calculus notation and rewrite the above as

$$[\hat{p}, \hat{q}^n] = -in\hat{q}^{n-1}\hbar = -i\hbar \left( \frac{\partial}{\partial \hat{q}} \hat{q}^n \right). \quad (42)$$

As mentioned earlier below (32), the derivative with respect to an operator has no meaning unless the operator acts on its eigenvector. Consequently, the above can be rewritten as

$$\begin{aligned} [\hat{p}, \hat{q}^n]|q\rangle &= -in\hat{q}^{n-1}\hbar|q\rangle \\ &= -in\hat{q}^{n-1}\hbar|q\rangle \\ &= -i\hbar \left( \frac{\partial}{\partial q} q^n \right) |q\rangle \\ &= -i\hbar \left( \frac{\partial}{\partial \hat{q}} \hat{q}^n \right) |q\rangle. \end{aligned} \quad (43)$$

In the above,  $|q\rangle$  is the eigenvector of the position operator  $\hat{q}$  with eigenvalue  $q$ , namely, that  $\hat{q}|q\rangle = q|q\rangle$ . It is to be noted that the  $\frac{\partial}{\partial \hat{q}}$  operator above acts only on  $\hat{q}^n$ , and nothing beyond to its right.

One can expand<sup>3</sup>

$$\begin{aligned} H(\hat{p}, \hat{q}) &= H_0(\hat{p}, 0) + H_1(\hat{p}, 0)\hat{q} + H_2(\hat{p}, 0)\hat{q}^2 \\ &\quad + H_3(\hat{p}, 0)\hat{q}^3 + \dots \end{aligned} \quad (44)$$

Then, it is clear that

$$[\hat{p}, \hat{H}] = -i\hbar \frac{\partial}{\partial \hat{q}} H(\hat{p}, \hat{q}). \quad (45)$$

Similarly, one can show that

$$[\hat{q}, \hat{H}] = i\hbar \frac{\partial}{\partial \hat{p}} H(\hat{p}, \hat{q}). \quad (46)$$

<sup>3</sup>This expansion may not exist, but for a Hamiltonian that is quadratic in  $\hat{p}$  and  $\hat{q}$ , it exists.

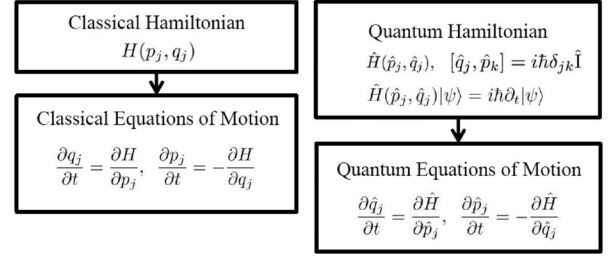

Fig. 1. (Left) Classical Hamiltonian and the classical equations of motion. (Right) Quantum Hamiltonian and the quantum equations of motion. The quantum Hamiltonian is obtained from the classical Hamiltonian by elevating the conjugate variables  $p_j$  and  $q_j$  to become quantum operator and endowing them with a commutation relation. The commutator induces derivative operator, making the quantum equations of motion strikingly similar to the classical ones. Unlike previous presentations, no mode decomposition is needed to obtain the quantum equations of motion.

Hence, (37) can then be rewritten as

$$\frac{\partial \hat{q}}{\partial t} = \frac{\partial H(\hat{p}, \hat{q})}{\partial \hat{p}} \quad \frac{\partial \hat{p}}{\partial t} = -\frac{\partial H(\hat{p}, \hat{q})}{\partial \hat{q}}. \quad (47)$$

The above are just the Hamilton equations for a quantum system: they bear striking similarities to the classical Hamilton equations of motion. It is clear from (44) that functions of operators are themselves operators. Hence, we neglect to put the  $\hat{\cdot}$  above the  $H$  in  $H(\hat{p}, \hat{q})$ , since they are obviously operators. It is to be noted that (47) does not involve  $\hbar$ , but  $\hbar$  surfaces in the coordinate representation of the operator  $\hat{p}$  in (39). In addition, one needs to take the expectation value of (47) to arrive at their classical analog.

Therefore, the procedure for obtaining the quantum equations of motion is clear. First, the classical Hamiltonian for the system is derived. Then, the conjugate variables, in this case, position  $q$  and momentum  $p$ , are elevated to become quantum operators  $\hat{q}$  and  $\hat{p}$ . In turn, the Hamiltonian becomes a quantum operator as well. Then, the quantum equations of motion have the same algebra as the classical equations of motion as in (47). A summary of this quantization procedure is given in Fig. 1. This procedure and its modification are used mainly in this work.

Very similar to (15), which eventually leads to (1)–(3), it can be shown that for a quantum harmonic oscillator (see Appendix C in Part II for details)

$$\begin{aligned} \hat{q}(t) &= \hat{b}_1 \cos(\Omega t) + \hat{b}_2 \sin(\Omega t), \\ \hat{p}(t) &= -m\Omega \hat{b}_1 \sin(\Omega t) + m\Omega \hat{b}_2 \cos(\Omega t). \end{aligned} \quad (48)$$

Since  $\hat{q}$  and  $\hat{p}$  are operators representing observables in the Heisenberg picture, they are time dependent and Hermitian. However,  $\hat{b}_1$  and  $\hat{b}_2$  are also Hermitian but time independent and not necessary commuting. It is to be reminded these operators act on a state vector  $|\psi_0\rangle$  defined in (33). Hence,  $\hat{q}(t)|\psi_0\rangle$  represents a new state vector of infinite dimension. With quantum interpretation, this indicates that the observable  $\hat{q}$  is probabilistic with infinite possible values [8]. But its average value is given by  $\langle \psi_0 | \hat{q}(t) | \psi_0 \rangle$ .

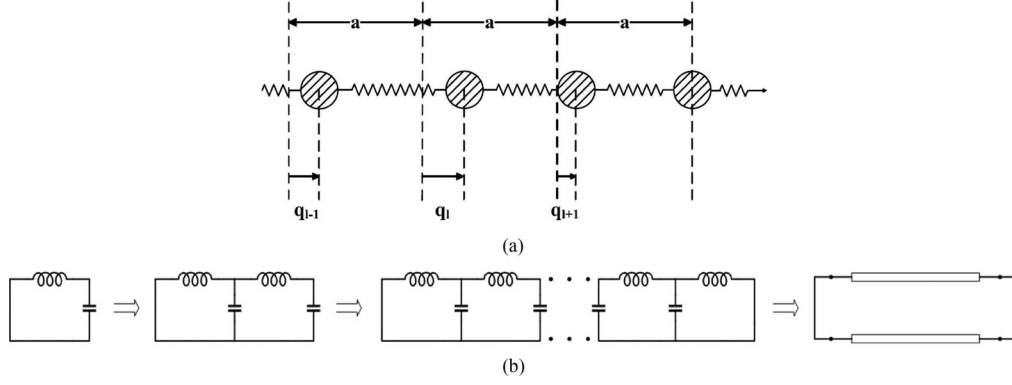

Fig. 2. (a) Lumped masses coupled by springs to form coupled harmonic oscillators. (b) Lumped element circuit has  $N$  modes, but a transmission line has infinitely many modes.

## VII. COUPLED HARMONIC OSCILLATORS

A lone harmonic oscillator can only have one resonant frequency. With two coupled harmonic oscillators, two resonant frequencies are possible, corresponding to odd and even couplings between the two oscillators. With a cluster of  $N$  coupled harmonic oscillators,  $N$  resonant frequencies are possible. With infinitely many harmonic oscillators, infinitely many resonant frequencies are possible. One can use a simple  $LC$  tank circuit and then a cluster of  $LC$  tank circuits to convince oneself of this fact [61] (see Fig. 2).

Assuming that vacuum is filled with harmonic oscillators formed by e-p pairs, then Maxwell's equations provide the coupling between these harmonic oscillators. For instance, in a lossless electromagnetic cavity, there are infinitely many possible resonant modes with different resonant frequencies, which are discretely spaced on the real frequency line. As the size of the cavity enlarges, the spacings between these discrete modes become smaller, and eventually, they become a continuum of modes on the real frequency line. Since this problem of coupled harmonic oscillator is complicated, it is more easily studied with Hamiltonian mechanics. Also, the Hamiltonian description of these coupled harmonic oscillators is needed to connect them to quantum mechanics. For simplicity, the free-space case for homogeneous isotropic medium case will be presented first.

### A. Decoupled Potential Equations

The Lorenz gauge treats space and time on the same footing, which is more in line with special relativity [64]. For free-space homogeneous media, it is

$$\nabla \cdot \mathbf{A} = -\partial_t \Phi \quad (49)$$

where  $\partial_t = \partial/\partial t$ , and for simplicity,  $\mu = \epsilon = 1$  has been assumed. Then, Maxwell's equations reduce to two decoupled potential equations

$$\nabla^2 \Phi - \partial_t^2 \Phi = -\rho \quad (50)$$

$$\nabla \times \nabla \times \mathbf{A} + \partial_t^2 \mathbf{A} - \nabla(\nabla \cdot \mathbf{A}) = \mathbf{J}. \quad (51)$$

The Coulomb gauge is rather popular in many works, and hence, the use of Lorenz gauge makes this work quite different. But

Coulomb gauge can be thought of as a special case of the Lorenz gauge: 1) when the system is slowly time varying compared to its spatial variation, namely,  $\partial_t \approx 0$ , or 2) when  $\Phi = 0$ . The latter is also called the  $\Phi = 0$  gauge and is possible when  $\nabla \cdot \mathbf{J} = 0$ , or  $\mathbf{J} = 0$  so that  $\rho = 0$ , and there is no source at infinity to excite a  $\Phi$  field. In the following, the source-free case will be assumed.

### B. Hamiltonian for the Scalar Potential

Before embarking on the vector potential wave equation, it is prudent to discuss the derivation of the Hamiltonian for the scalar potential wave equation as described by (50) for the source-free case, namely,  $\rho = 0$ . The wave system is due to oscillations traveling through space coupled by infinitely many harmonic oscillators. Then, the Hamiltonian that will yield the equation of motion in (50) (without the source term) is the functional

$$H_\Phi = \frac{1}{2} \int d\mathbf{r} \left[ (\partial_t \Phi(\mathbf{r}, t))^2 + (\nabla \Phi(\mathbf{r}, t))^2 \right]. \quad (52)$$

There is no clear rhyme or reason that the above is the correct Hamiltonian. But it actually is the Hamiltonian for an infinite set of coupled harmonic oscillators in the continuum world. The Hamiltonian for a lone harmonic oscillator has been derived before as the total energy of the oscillator and, likewise, for the coupled harmonic oscillators. To see the physics and analogy more clearly, the Hamiltonian for the discrete coupled harmonic oscillators will be presented next [12], [62].

1) *Discrete Coupled Harmonic Oscillators:* The discrete analog of the above Hamiltonian is

$$H_\Phi = \frac{1}{2} \sum_i \left\{ [\partial_t \Phi(\mathbf{r}_i, t)]^2 + \sum_j [\Phi(\mathbf{r}_j, t) K_{ji} \Phi(\mathbf{r}_i, t)] \right\}. \quad (53)$$

The matrix  $K_{ji}$  is equivalent to the stiffness matrix in mechanics, which is usually symmetric. And the above discrete form can be derived from the continuum form using finite-difference approximations, for example. Here,  $K_{ji}$  usually is sparse nondiagonal, because it involves only near-neighbor interactions or coupling. (There is a  $\Delta V$  term that follows from  $d\mathbf{r}$  that is ignored for simplicity.) To connect with the case of the lone harmonic oscillator,



the Hamiltonian for such a system is suggestively written as

$$H_\Phi = \frac{1}{2} \sum_i \left\{ p_i^2(t) + \sum_j [q_j(t) K_{ji} q_i(t)] \right\} \quad (54)$$

where now  $q_i(t) = \Phi(\mathbf{r}_i, t)$ , and  $p_i(t) = \partial_t \Phi(\mathbf{r}_i, t)$  variables to remind the reader of the lone harmonic oscillator case. But there are many coupled harmonic oscillators here, each at position  $\mathbf{r}_i$  described by the momentum  $p_i(t)$  and displacement  $q_i(t)$ .

In this discrete picture, where it is connected back to the lone harmonic oscillator case, the physical meanings of the terms are clear: The first term in the square bracket represents the kinetic energy of the particles, each at position  $\mathbf{r}_i$  or  $i$ , and the second term represents the potential energy of the particles due to self-term and the mutual coupling between them, in the sense of a generalized Hooke's law.

In the above Hamiltonian,  $p_i(t)$  and  $q_i(t)$  for different  $i$ 's are to be regarded as independent variables, just as the lone harmonic oscillator case. However, they are constrained to vary as a function of time so as to conserve energy, giving rise to the Hamilton equations of motion. Perturbing each particle independently of each other yields that

$$\frac{\partial q_i}{\partial t} = \frac{\partial H}{\partial p_i} \quad \frac{\partial p_i}{\partial t} = -\frac{\partial H}{\partial q_i}. \quad (55)$$

Only two degrees of freedom, momentum  $p_i$  and position  $q_i$ , are given per particle to retain this as a scalar problem.

Taking the first variation of the above with respect to  $\delta p_i(t)$  and  $\delta q_i(t)$  yields

$$\delta H_\Phi = \sum_i \left\{ p_i(t) \delta p_i(t) + \sum_j [q_j(t) K_{ji} \delta q_i(t)] \right\}. \quad (56)$$

Dividing the above by  $\delta p_{i'}$  and  $\delta q_{i'}$ , respectively, and letting these variations tend to zero, then

$$\frac{\partial H_\Phi}{\partial p_{i'}} = \sum_i \left\{ p_i(t) \frac{\partial p_i}{\partial p_{i'}} + \sum_j \left[ q_j(t) K_{ji} \frac{\partial q_i}{\partial p_{i'}} \right] \right\} \quad (57)$$

$$\frac{\partial H_\Phi}{\partial q_{i'}} = \sum_i \left\{ p_i(t) \frac{\partial p_i}{\partial q_{i'}} + \sum_j \left[ q_j(t) K_{ji} \frac{\partial q_i}{\partial q_{i'}} \right] \right\}. \quad (58)$$

It is clear that due to the independence of  $q_i$  and  $p_i$ , and that these are independent particles [62],

$$\frac{\partial p_i}{\partial p_{i'}} = \frac{\partial q_i}{\partial q_{i'}} = \delta_{ii'} \quad \frac{\partial q_i}{\partial p_{i'}} = \frac{\partial p_i}{\partial q_{i'}} = 0 \quad (59)$$

where  $\delta_{ii'}$  is the Kronecker delta function. Upon applying the sifting property of the Kronecker delta function, and the Hamilton equations of motion, one has

$$\frac{\partial q_i(t)}{\partial t} = p_i(t) \quad \frac{\partial p_i(t)}{\partial t} = -\sum_j K_{ij} q_j(t) \quad (60)$$

where  $K_{ij}$  is a symmetric matrix. The above are the equations of motion of the discrete coupled harmonic oscillators. Combining the above yields the equation of motion

$$\frac{\partial^2 q_i(t)}{\partial t^2} = -\sum_j K_{ij} q_j(t) \quad (61)$$

which bears similarity to (50).

2) *Continuum Case:* Now, for the continuum case, functional derivatives are involved. Since  $\partial_t \Phi(\mathbf{r}, t)$  is independent of  $\Phi(\mathbf{r}, t)$ , just as  $q_i$  and  $p_i$  in the discrete case, one gives it a new name  $\Pi_s(\mathbf{r}, t) = \partial_t \Phi(\mathbf{r}, t)$  known as the conjugate momentum, because this part is equivalent to  $p_i(t)$  in the discrete case, which represents momentum. The Hamiltonian then becomes [62]

$$H_\Phi = \frac{1}{2} \int d\mathbf{r} \left[ (\Pi_s(\mathbf{r}, t))^2 + (\nabla \Phi(\mathbf{r}, t))^2 \right]. \quad (62)$$

The first variation due to a perturbation in the field of the Hamiltonian defined in (62) is

$$\delta H_\Phi = \int d\mathbf{r} \left[ \Pi_s(\mathbf{r}, t) \delta \Pi_s(\mathbf{r}, t) + \nabla \Phi(\mathbf{r}, t) \cdot \nabla \delta \Phi(\mathbf{r}, t) \right]. \quad (63)$$

Upon using integration by parts, it becomes

$$\delta H_\Phi = \int d\mathbf{r} \left[ \Pi_s(\mathbf{r}, t) \delta \Pi_s(\mathbf{r}, t) - \nabla^2 \Phi(\mathbf{r}, t) \delta \Phi(\mathbf{r}, t) \right]. \quad (64)$$

From the above, the functional derivatives [12], [62], [63] are introduced to give

$$\frac{\delta H_\Phi}{\delta \Phi(\mathbf{r}', t)} = \int d\mathbf{r} \left[ \Pi_s(\mathbf{r}, t) \frac{\delta \Pi_s(\mathbf{r}, t)}{\delta \Phi(\mathbf{r}', t)} - \nabla^2 \Phi(\mathbf{r}, t) \frac{\delta \Phi(\mathbf{r}, t)}{\delta \Phi(\mathbf{r}', t)} \right] \quad (65)$$

$$\frac{\delta H_\Phi}{\delta \Pi_s(\mathbf{r}', t)} = \int d\mathbf{r} \left[ \Pi_s(\mathbf{r}, t) \frac{\delta \Pi_s(\mathbf{r}, t)}{\delta \Pi_s(\mathbf{r}', t)} - \nabla^2 \Phi(\mathbf{r}, t) \frac{\delta \Phi(\mathbf{r}, t)}{\delta \Pi_s(\mathbf{r}', t)} \right]. \quad (66)$$

From the analog of the discrete case, one can make use of the following properties of functional derivatives to simplify the above. They are

$$\begin{aligned} \frac{\delta \Phi(\mathbf{r}, t)}{\delta \Phi(\mathbf{r}', t)} &= \frac{\delta \Pi_s(\mathbf{r}, t)}{\delta \Pi_s(\mathbf{r}', t)} = \delta(\mathbf{r} - \mathbf{r}') \\ \frac{\delta \Phi(\mathbf{r}, t)}{\delta \Pi_s(\mathbf{r}', t)} &= \frac{\delta \Pi_s(\mathbf{r}, t)}{\delta \Phi(\mathbf{r}', t)} = 0. \end{aligned} \quad (67)$$

These are the continuum analog of (59) in the discrete case. In other words, the Kronecker delta function in (59) becomes the Dirac delta function in the continuum case. Finally, using the above functional derivatives (67) in (65) and (66) gives rise to

$$\frac{\delta H_\Phi}{\delta \Phi(\mathbf{r}', t)} = -\nabla'^2 \Phi(\mathbf{r}', t) \quad (68)$$

$$\frac{\delta H_\Phi}{\delta \Pi_s(\mathbf{r}', t)} = \Pi_s(\mathbf{r}', t). \quad (69)$$

The Hamilton equations of motion analogous to the discrete case expounded in (55) are

$$\frac{\partial \Phi(\mathbf{r}, t)}{\partial t} = \frac{\delta H_\Phi}{\delta \Pi_s(\mathbf{r}, t)} \quad \frac{\partial \Pi_s(\mathbf{r}, t)}{\partial t} = -\frac{\delta H_\Phi}{\delta \Phi(\mathbf{r}, t)}. \quad (70)$$

Applying the above then gives

$$\frac{\partial \Phi(\mathbf{r}, t)}{\partial t} = \Pi_s(\mathbf{r}, t) \quad \frac{\partial \Pi_s(\mathbf{r}, t)}{\partial t} = \nabla^2 \Phi(\mathbf{r}, t). \quad (71)$$

Combining the above together yields the wave equation as the equation of motion for the scalar potential, namely,

$$\partial_t^2 \Phi(\mathbf{r}, t) - \nabla^2 \Phi(\mathbf{r}, t) = 0. \quad (72)$$



This is the continuum analog of (61).

### C. Hamiltonian for Vector Potential

Now that one is armed with the necessary tools, the Hamiltonian can be derived for the vector potential field. The complication here is that vector fields will be involved. Assuming the source-free case again, the Hamiltonian that will yield the equation of motion in (51) is

$$H_A = \frac{1}{2} \int d\mathbf{r} \left[ (\boldsymbol{\Pi}(\mathbf{r}, t))^2 + (\nabla \times \mathbf{A}(\mathbf{r}, t))^2 + (\nabla \cdot \mathbf{A}(\mathbf{r}, t))^2 \right] \quad (73)$$

where  $\boldsymbol{\Pi}(\mathbf{r}, t) = \partial_t \mathbf{A}(\mathbf{r}, t)$  is the conjugate momentum. To show this, the first variation of the above is taken with respect to field perturbations  $\delta \boldsymbol{\Pi}(\mathbf{r}, t)$  and  $\delta \mathbf{A}(\mathbf{r}, t)$ , to give

$$\begin{aligned} \delta H_A = \int d\mathbf{r} & \left[ \boldsymbol{\Pi}(\mathbf{r}, t) \cdot \delta \boldsymbol{\Pi}(\mathbf{r}, t) + (\nabla \times \mathbf{A}(\mathbf{r}, t)) \right. \\ & \left. \cdot (\nabla \times \delta \mathbf{A}(\mathbf{r}, t)) + (\nabla \cdot \mathbf{A}(\mathbf{r}, t)) (\nabla \cdot \delta \mathbf{A}(\mathbf{r}, t)) \right]. \end{aligned} \quad (74)$$

Using integration by parts on the second and third terms, the above becomes

$$\begin{aligned} \delta H_A = \int d\mathbf{r} & \left[ \boldsymbol{\Pi}(\mathbf{r}, t) \cdot \delta \boldsymbol{\Pi}(\mathbf{r}, t) + [\nabla \times \nabla \times \mathbf{A}(\mathbf{r}, t) - \nabla \nabla \right. \\ & \left. \cdot \mathbf{A}(\mathbf{r}, t)] \cdot \delta \mathbf{A}(\mathbf{r}, t) \right]. \end{aligned} \quad (75)$$

Now, taking the functional derivative of the above functional with respect to the vector functions  $\boldsymbol{\Pi}$  and  $\mathbf{A}$  gives

$$\begin{aligned} \frac{\delta H_A}{\delta \boldsymbol{\Pi}(\mathbf{r}', t)} = \int d\mathbf{r} & \left[ \boldsymbol{\Pi}(\mathbf{r}, t) \cdot \frac{\delta \boldsymbol{\Pi}(\mathbf{r}, t)}{\delta \boldsymbol{\Pi}(\mathbf{r}', t)} + (\nabla \times \nabla \times \mathbf{A}(\mathbf{r}, t)) \right. \\ & \left. - \nabla \nabla \cdot \mathbf{A}(\mathbf{r}, t) \right] \cdot \frac{\delta \mathbf{A}(\mathbf{r}, t)}{\delta \boldsymbol{\Pi}(\mathbf{r}', t)} \end{aligned} \quad (76)$$

$$\begin{aligned} \frac{\delta H}{\delta \mathbf{A}(\mathbf{r}', t)} = \int d\mathbf{r} & \left[ \boldsymbol{\Pi}(\mathbf{r}, t) \cdot \frac{\delta \boldsymbol{\Pi}(\mathbf{r}, t)}{\delta \mathbf{A}(\mathbf{r}', t)} + (\nabla \times \nabla \times \mathbf{A}(\mathbf{r}, t)) \right. \\ & \left. - \nabla \nabla \cdot \mathbf{A}(\mathbf{r}, t) \right] \cdot \frac{\delta \mathbf{A}(\mathbf{r}, t)}{\delta \mathbf{A}(\mathbf{r}', t)}. \end{aligned} \quad (77)$$

It is worth taking a break to ponder the meaning of a functional derivative with respect to say a vector function  $\mathbf{A}(\mathbf{r}, t)$  [63]. Since vector function consists of three scalar functions  $A_i(\mathbf{r}, t)$ ,  $i = 1, 2, 3$ , a functional of a vector function is, in actual fact, a functional of three independent scalar functions. The functional derivative with respect to a vector function then implies that it is taken with respect to three scalar functions, hence generating a three-vector (three-component vector). Hence, the left-hand side of the above should be three-vectors. And the functional derivative of a vector function with respect to another vector function should produce a  $3 \times 3$  tensor. Consequently, it

can be quite easily shown that

$$\begin{aligned} \frac{\delta \mathbf{A}(\mathbf{r}, t)}{\delta \mathbf{A}(\mathbf{r}', t)} &= \frac{\delta \boldsymbol{\Pi}(\mathbf{r}, t)}{\delta \boldsymbol{\Pi}(\mathbf{r}', t)} = \bar{\mathbf{I}} \delta(\mathbf{r} - \mathbf{r}') \\ \frac{\delta \mathbf{A}(\mathbf{r}, t)}{\delta \boldsymbol{\Pi}(\mathbf{r}', t)} &= \frac{\delta \boldsymbol{\Pi}(\mathbf{r}, t)}{\delta \mathbf{A}(\mathbf{r}', t)} = 0. \end{aligned} \quad (78)$$

The above are the vector analog of (67) for the continuum case, and (59) for the discrete case. Therefore, the above functional derivatives in (76) and (77) finally become

$$\frac{\delta H_A}{\delta \boldsymbol{\Pi}(\mathbf{r}', t)} = \boldsymbol{\Pi}(\mathbf{r}', t) \quad (79)$$

$$\frac{\delta H_A}{\delta \mathbf{A}(\mathbf{r}', t)} = \nabla' \times \nabla' \times \mathbf{A}(\mathbf{r}', t) - \nabla' \nabla' \cdot \mathbf{A}(\mathbf{r}', t). \quad (80)$$

The Hamilton equations of motion in this case, analogous to (55) and (70), are

$$\frac{\partial \mathbf{A}(\mathbf{r}, t)}{\partial t} = \frac{\delta H_A}{\delta \boldsymbol{\Pi}(\mathbf{r}, t)} \quad \frac{\partial \boldsymbol{\Pi}(\mathbf{r}, t)}{\partial t} = -\frac{\delta H_A}{\delta \mathbf{A}(\mathbf{r}, t)}. \quad (81)$$

Consequently, the above becomes

$$\begin{aligned} \frac{\partial \mathbf{A}(\mathbf{r}, t)}{\partial t} &= \boldsymbol{\Pi}(\mathbf{r}, t) \\ \frac{\partial \boldsymbol{\Pi}(\mathbf{r}, t)}{\partial t} &= -\nabla \times \nabla \times \mathbf{A}(\mathbf{r}, t) + \nabla \nabla \cdot \mathbf{A}(\mathbf{r}, t). \end{aligned} \quad (82)$$

Combining the above yields the vector wave equation as the equation of motion for the vector potential, namely,

$$\partial_t^2 \mathbf{A}(\mathbf{r}, t) + \nabla \times \nabla \times \mathbf{A}(\mathbf{r}, t) - \nabla \nabla \cdot \mathbf{A}(\mathbf{r}, t) = 0. \quad (83)$$

### D. Total Hamiltonian for Free Space

The total Hamiltonian in Lorenz gauge is the Hamiltonian due to the vector potential minus the Hamiltonian due to the scalar potential. In other words,

$$H = H_A - H_\Phi. \quad (84)$$

The minus sign is necessary because the above can be easily manipulated, by invoking Lorenz gauge and integration by parts, to the form so that

$$H = \frac{1}{2} \int d\mathbf{r} \left[ \mathbf{E}^2(\mathbf{r}, t) + \mathbf{B}^2(\mathbf{r}, t) \right]. \quad (85)$$

The above integrand is always positive definite as it represents the total energy stored in the electromagnetic field. The minus sign in (84) also means that the energy stored in the vector potential part is in excess of the total electromagnetic energy, and hence, the energy stored in the scalar potential part needs to be removed. The above will be generalized to the anisotropic inhomogeneous medium case in a later section in Part II. This excess energy shall be explained in terms of longitudinal modes later in the mode decomposition section in Part II. Also, it is *de rigueur*, as otherwise, one cannot derive (85) from (84).

## VIII. COUPLED QUANTUM HARMONIC OSCILLATORS

The algebra derived in Section VI-A is clear for a lone quantum harmonic oscillator. But for wave phenomenon, the quantum harmonic oscillators are coupled. The commutator of the

quantum operators induces an algebra for quantum harmonic oscillators that is very similar to the classical Hamiltonian in (47). Hence, using the equations of motion that have been derived for the quantum case, namely, (47), the algebra for deriving the equations of motion is surprisingly similar to that of the classical case. The discrete coupled quantum harmonic oscillator case will be treated first, followed by the continuum cases. In the continuum cases, the scalar potential case as well as the vector potential case will be studied.

### A. Discrete Coupled Quantum Harmonic Oscillators

First, the classical Hamiltonian for this system is elevated to quantum Hamiltonian by elevating the conjugate variables,  $p_i(t)$  and  $q_i(t)$ , to become quantum operators. Then, the quantum Hamiltonian for such a system from (54) is

$$\hat{H}_\Phi = \frac{1}{2} \sum_i \left\{ \hat{p}_i^2(t) + \sum_j [\hat{q}_j(t) K_{ji} \hat{q}_i(t)] \right\}. \quad (86)$$

Next, for the case of discrete coupled quantum harmonic oscillators, the commutator between the conjugate operators is

$$[\hat{q}_i(t), \hat{p}_j(t)] = i\hbar \hat{I} \delta_{ij}. \quad (87)$$

The above equal-time commutator induces similar algebra as in the lone quantum harmonic oscillator case, but with the presence of the Kronecker delta function  $\delta_{ij}$  implying further that the oscillators  $i$  and  $j$  are independent of each other. Similar to the lone harmonic oscillator case, it can be shown that

$$\begin{aligned} [\hat{p}_{i'}, \hat{q}_i^n] &= -in\delta_{i'i} \hat{q}_i^{n-1} \hbar \\ &= -i\hbar \frac{\partial}{\partial \hat{q}_{i'}} \hat{q}_i^n \rightarrow [\hat{p}_{i'}, \hat{H}_\Phi] \\ &= -i\hbar \frac{\partial}{\partial \hat{q}_{i'}} \hat{H}_\Phi \\ &= i\hbar \partial_t \hat{p}_{i'}(t) \end{aligned} \quad (88)$$

$$\begin{aligned} [\hat{q}_{i'}, \hat{p}_i^n] &= in\delta_{i'i} \hat{p}_i^{n-1} \hbar \\ &= i\hbar \frac{\partial}{\partial \hat{p}_{i'}} \hat{p}_i^n \rightarrow [\hat{q}_{i'}, \hat{H}_\Phi] \\ &= i\hbar \frac{\partial}{\partial \hat{p}_{i'}} \hat{H}_\Phi \\ &= i\hbar \partial_t \hat{q}_{i'}(t). \end{aligned} \quad (89)$$

The above yields the same algebra as the classical Hamiltonian case, yielding equations of motion very similar to (55), but with the conjugate variables replaced by operators. Going through the same algebra similar to the classical case, the equations of motion of the discrete coupled quantum harmonic oscillators become

$$\frac{\partial \hat{q}_i(t)}{\partial t} = \hat{p}_i(t) \quad \frac{\partial \hat{p}_i(t)}{\partial t} = - \sum_j K_{ij} \hat{q}_j(t) \quad (90)$$

where  $K_{ij}$  is a symmetric matrix. Combining the above yields

$$\frac{\partial^2 \hat{q}_i(t)}{\partial t^2} = - \sum_j K_{ij} \hat{q}_j(t). \quad (91)$$

The above treatment is mainly for pedagogy. To treat a true Maxwellian system, both the scalar and vector potentials need to be quantized and treated as quantum operators. But the algebra will be similar. More important, the algebra is also similar to that for classical Hamiltonian.

### B. Scalar Potential Case

In the scalar potential case, the Hamiltonian from (62) is first elevated to be quantum operators by elevating the conjugate variables,  $\Pi_s(\mathbf{r}, t)$  and  $\Phi(\mathbf{r}, t)$ , in it to become quantum operators, namely,

$$\hat{H}_\Phi = \frac{1}{2} \int d\mathbf{r} \left[ \hat{\Pi}_s^2(\mathbf{r}, t) + \left( \nabla \hat{\Phi}(\mathbf{r}, t) \right)^2 \right]. \quad (92)$$

Then, the commutator, analogous to the discrete harmonic oscillator case as in (87), becomes

$$\left[ \hat{\Pi}_s(\mathbf{r}, t), \hat{\Phi}(\mathbf{r}', t) \right] = i\hbar \delta(\mathbf{r} - \mathbf{r}') \hat{I} \quad (93)$$

where the Kronecker delta function becomes a Dirac delta function in the continuum case. With this commutation relation, similar to the discrete case in (88) and (89), it is quite easy to show that

$$\begin{aligned} \left[ \hat{\Pi}_s(\mathbf{r}', t), \hat{\Phi}^n(\mathbf{r}, t) \right] &= -i\hbar \delta(\mathbf{r} - \mathbf{r}') n \hat{\Phi}^{n-1}(\mathbf{r}, t) \\ &= -i\hbar \frac{\delta \hat{\Phi}^n(\mathbf{r}, t)}{\delta \hat{\Phi}(\mathbf{r}', t)} \rightarrow \left[ \hat{\Pi}_s(\mathbf{r}', t), \hat{H}_\Phi \right] \\ &= -i\hbar \frac{\delta \hat{H}_\Phi}{\delta \hat{\Phi}(\mathbf{r}', t)} \\ &= i\hbar \partial_t \hat{\Pi}_s(\mathbf{r}', t) \end{aligned} \quad (94)$$

$$\begin{aligned} \left[ \hat{\Phi}(\mathbf{r}', t), \hat{\Pi}_s^n(\mathbf{r}, t) \right] &= i\hbar \delta(\mathbf{r} - \mathbf{r}') n \hat{\Pi}_s^{n-1}(\mathbf{r}, t) \\ &= i\hbar \frac{\delta \hat{\Pi}_s^n(\mathbf{r}, t)}{\delta \hat{\Pi}_s(\mathbf{r}', t)} \rightarrow \left[ \hat{\Phi}(\mathbf{r}', t), \hat{H}_\Phi \right] \\ &= i\hbar \frac{\delta \hat{H}_\Phi}{\delta \hat{\Pi}_s(\mathbf{r}', t)} \\ &= i\hbar \partial_t \hat{\Phi}(\mathbf{r}', t) \end{aligned} \quad (95)$$

where the functional derivatives of operators have meaning only when they act on the eigenvectors of these operators. Furthermore, by noting that

$$\partial_t \hat{\Pi}_s(\mathbf{r}, t) = \frac{\delta \hat{\Pi}_s(\mathbf{r}, t)}{\delta \hat{\Pi}_s(\mathbf{r}', t)} \partial_t \hat{\Pi}_s(\mathbf{r}', t) = \delta(\mathbf{r} - \mathbf{r}') \partial_t \hat{\Pi}_s(\mathbf{r}', t) \quad (96)$$

the Hamilton equations very similar to the classical case (70) are obtained, except for the replacements of variables with operators. Then, by going through similar algebra as in the classical case, one gets

$$\frac{\partial \hat{\Phi}(\mathbf{r}, t)}{\partial t} = \hat{\Pi}_s(\mathbf{r}, t) \quad \frac{\partial \hat{\Pi}_s(\mathbf{r}, t)}{\partial t} = \nabla^2 \hat{\Phi}(\mathbf{r}, t). \quad (97)$$

The above together yield the wave equation as the equation of motion for the operator  $\hat{\Phi}(\mathbf{r}, t)$ , namely,

$$\partial_t^2 \hat{\Phi}(\mathbf{r}, t) - \nabla^2 \hat{\Phi}(\mathbf{r}, t) = 0. \quad (98)$$

The above operator acts on a state vector  $|\psi_\Phi(t=0)\rangle$  that describes the initial state of the quantum system representing the coupled harmonic oscillators.

### C. Vector Potential Case

The commutation relation for the vector potential case is

$$\left[ \hat{\Pi}_i(\mathbf{r}, t), \hat{A}_j(\mathbf{r}', t) \right] = i\hbar \delta(\mathbf{r} - \mathbf{r}') \delta_{ij} \hat{I} \quad (99)$$

where  $i$  and  $j$  now represent components of the three-vectors as in index notation. The above can also be written more succinctly as

$$\left[ \hat{\mathbf{\Pi}}(\mathbf{r}, t), \hat{\mathbf{A}}(\mathbf{r}', t) \right] = i\hbar \delta(\mathbf{r} - \mathbf{r}') \hat{\mathbf{I}}. \quad (100)$$

With this commutation relation, it is quite easy to show, similar to the scalar case, that

$$\begin{aligned} \left[ \hat{\Pi}_i(\mathbf{r}', t), \hat{A}_j^n(\mathbf{r}, t) \right] &= -i\hbar \delta(\mathbf{r} - \mathbf{r}') \delta_{ij} n \hat{A}_j^{n-1}(\mathbf{r}, t) \\ &= -i\hbar \frac{\delta \hat{A}_j^n(\mathbf{r}, t)}{\delta \hat{A}_i(\mathbf{r}', t)} \rightarrow \left[ \hat{\mathbf{\Pi}}(\mathbf{r}', t), \hat{H}_A \right] \\ &= -i\hbar \frac{\delta \hat{H}_A}{\delta \hat{\mathbf{A}}(\mathbf{r}', t)} \\ &= i\hbar \partial_t \hat{\mathbf{\Pi}}(\mathbf{r}', t) \end{aligned} \quad (101)$$

$$\begin{aligned} \left[ \hat{A}_j(\mathbf{r}', t), \hat{\Pi}_i^n(\mathbf{r}, t) \right] &= i\hbar \delta(\mathbf{r} - \mathbf{r}') \delta_{ij} n \hat{\Pi}_i^{n-1}(\mathbf{r}, t) \\ &= -i\hbar \frac{\delta \hat{\Pi}_i^n(\mathbf{r}, t)}{\delta \hat{\Pi}_j(\mathbf{r}', t)} \rightarrow \left[ \hat{\mathbf{A}}(\mathbf{r}', t), \hat{H}_A \right] \\ &= i\hbar \frac{\delta \hat{H}_A}{\delta \hat{\mathbf{\Pi}}(\mathbf{r}', t)} \\ &= i\hbar \partial_t \hat{\mathbf{A}}(\mathbf{r}', t). \end{aligned} \quad (102)$$

In other words, the commutator acts like a derivative operator with respect to each other just like the lone harmonic oscillator case. The Kronecker delta functions above imply that different components of a vector are independent. Moreover, the Hamilton equations of motion very similar to (81) can be obtained, except that variables are replaced by operators. The corresponding quantum Hamiltonian for vector potential is

$$\hat{H}_A = \frac{1}{2} \int d\mathbf{r} \left[ \left( \hat{\mathbf{\Pi}}(\mathbf{r}, t) \right)^2 + \left( \nabla \times \hat{\mathbf{A}}(\mathbf{r}, t) \right)^2 + \left( \nabla \cdot \hat{\mathbf{A}}(\mathbf{r}, t) \right)^2 \right] \quad (103)$$

where  $\hat{\mathbf{\Pi}}(\mathbf{r}, t) = \partial_t \hat{\mathbf{A}}(\mathbf{r}, t)$ . Consequently, the above becomes

$$\begin{aligned} \frac{\partial \hat{\mathbf{A}}(\mathbf{r}, t)}{\partial t} &= \hat{\mathbf{\Pi}}(\mathbf{r}, t) \\ \frac{\partial \hat{\mathbf{\Pi}}(\mathbf{r}, t)}{\partial t} &= -\nabla \times \nabla \times \hat{\mathbf{A}}(\mathbf{r}, t) + \nabla \nabla \cdot \hat{\mathbf{A}}(\mathbf{r}, t). \end{aligned} \quad (104)$$

The above yields the quantum wave equation as the equation of motion, namely,

$$-\partial_t^2 \hat{\mathbf{A}}(\mathbf{r}, t) - \nabla \times \nabla \times \hat{\mathbf{A}}(\mathbf{r}, t) + \nabla \nabla \cdot \hat{\mathbf{A}}(\mathbf{r}, t) = 0. \quad (105)$$

The above quantum operator acts on a state vector  $|\psi_A\rangle$  that describes the state of the quantum system representing the vector potential coupled harmonic oscillators.

The scalar potential and the vector potential are related to each other by the Lorenz gauge. The above exercise can be repeated with  $\mu \neq \varepsilon \neq 1$ . From the above equations of motion for the scalar and vector potential operators, the equations of motion in terms of the  $\hat{\mathbf{E}}(\mathbf{r}, t)$  and  $\hat{\mathbf{B}}(\mathbf{r}, t)$  can be derived, namely,

$$\begin{aligned} \nabla \times \hat{\mathbf{E}}(\mathbf{r}, t) &= -\partial_t \hat{\mathbf{B}}(\mathbf{r}, t) \quad \nabla \times \hat{\mathbf{B}}(\mathbf{r}, t) \\ &= \partial_t \hat{\mathbf{E}}(\mathbf{r}, t) \\ \nabla \cdot \hat{\mathbf{B}}(\mathbf{r}, t) &= 0 \quad \nabla \cdot \hat{\mathbf{D}}(\mathbf{r}, t) \\ &= 0. \end{aligned} \quad (106)$$

The above quantum operator equations have also been derived by [29] albeit using a rather different approach. These quantum operators operate on a state vector  $|\psi(t=0)\rangle$  that describes the initial state of the quantum system. The state vector evolves with time according to the Schrödinger equation

$$\hat{H}|\psi\rangle = i\hbar \partial_t |\psi\rangle \quad (107)$$

where  $\hat{H} = \hat{H}_A - \hat{H}_\Phi$ , and  $|\psi\rangle$  is a state vector that represents the state of this aggregate quantum system.

## IX. CONCLUSION

In Part I of this work, the importance of electromagnetic theory and its enduring legacy have been emphasized. The emerging interest in quantum effects in electromagnetics will permeate many areas. A comprehensive way to understand quantum electromagnetics has been presented. Hopefully, this knowledge is made more accessible to the electromagnetics community. The important quantum Hamilton equations of motion for quantum systems have been derived. From them, the quantum equations of motion for scalar and vector potentials, as well as the electromagnetic fields, can be easily arrived at.

In Part II, the generalization of quantization to the anisotropic inhomogeneous medium case will be presented. Moreover, the connection to the quantization via mode decomposition will be given. The quantization for the case when an impressed source is present and the role of Green's function will also be discussed.

## ACKNOWLEDGMENT

This work is dedicated to the memory of Shun Lien Chuang.

## REFERENCES

- [1] J. C. Maxwell, "A dynamical theory of the electromagnetic field," *Philos. Trans. Roy. Soc. Lond.*, vol. 155, pp. 459–512, Jan. 1865.
- [2] D. Yaghjian, "Reflections on Maxwell's treatise," *Prog. Electromagn. Res.*, vol. 149, pp. 217–249, 2014.
- [3] P. J. Nahin, *Oliver Heaviside: The Life, Work, and Times of an Electrical Genius of the Victorian Age*, Baltimore, MD, USA: The Johns Hopkins Univ. Press, 2002.

- [4] H. R. Hertz, "On the propagation velocity of electrodynamic effects," *Ann. Phys.*, vol. 270, no. 7, pp. 551–560, 1888.
- [5] J. F. Clauser, "Experimental distinction between the quantum and classical field-theoretic predictions for the photoelectric effect," *Phys. Rev. D, Part. Fields*, vol. 9, no. 4, pp. 853–860, Feb. 1974.
- [6] H. J. Kimble, M. Dagaenais, and L. Mandel, "Photon antibunching in resonance fluorescence," *Phys. Rev. Lett.*, vol. 39, no. 11, pp. 691–695, Sep. 1977.
- [7] A. Aspect, J. Dalibard, and G. Roger, "Experimental test of Bell's inequalities using time-varying analyzers," *Phys. Rev. Lett.*, vol. 49, no. 25, pp. 1804–1807, Dec. 1982.
- [8] D. J. Griffiths, *Introduction to Quantum Mechanics*. Harlow, U.K.: Pearson Educ., 2004.
- [9] D. A. B. Miller, *Quantum Mechanics for Scientists and Engineers*. New York, NY, USA: Cambridge Univ. Press, 2008.
- [10] C. J. Ryu, A. Y. Liu, W. E. I. Sha, and W. C. Chew, "Finite-difference time-domain simulation of the Maxwell-Schrödinger system," *IEEE J. Multiscale Multiphys. Computat. Techn.*, vol. 1, pp. 40–47, 2016.
- [11] Z.-L. Xiang, S. Ashhab, J. Q. You, and F. Nori, "Hybrid quantum circuits: Superconducting circuits interacting with other quantum systems," *Rev. Modern Phys.*, vol. 85, no. 2, pp. 623–653, Apr.–Jun. 2013.
- [12] C. Cohen-Tannoudji, J. Dupont-Roc, and G. Grynberg, *Atom-Photon Interactions: Basic Processes and Applications*. New York, NY, USA: Wiley, 1992.
- [13] S. Datta, *Quantum Transport: Atom to Transistor*. New York, NY, USA: Cambridge Univ. Press, 2005.
- [14] S. K. Lamoreaux, "Demonstration of the Casimir force in the 0.6 to 6  $\mu\text{m}$  range," *Phys. Rev. Lett.*, vol. 78, no. 1, pp. 5–8, Jan. 1997.
- [15] H. B. G. Casimir, "On the attraction between two perfectly conducting plates," *Kon. Ned. Akad. Wetensch. Proc.*, vol. 51, pp. 793–795, 1948.
- [16] H. B. G. Casimir and D. Polder, "The influence of retardation on the London-van der Waals forces," *Phys. Rev.*, vol. 73, pp. 360–372, Feb. 1948.
- [17] L. Novotny and B. Hecht, *Principles of Nano-Optics*. New York, NY, USA: Cambridge Univ. Press, 2008.
- [18] H. T. Dung, L. Knöll, and D. -G. Welsch, "Three-dimensional quantization of the electromagnetic field in dispersive and absorbing inhomogeneous dielectrics," *Phys. Rev. A, Gen. Phys.*, vol. 57, no. 5, pp. 3931–3942, May 1998.
- [19] S. Scheel and S. Y. Buhmann, "Macroscopic quantum electrodynamics concepts and applications," *Acta Phys. Slovaca*, vol. 58, no. 5, pp. 675–809, Oct. 2008.
- [20] C. T. Tai, *Dyadic Green Functions in Electromagnetic Theory*, vol. 272. Piscataway, NJ, USA: IEEE Press, 1994.
- [21] J. A. Kong, *Theory of Electromagnetic Waves*. New York, NY, USA: Wiley, 1986.
- [22] A. Ishimaru, *Electromagnetic Wave Propagation, Radiation, and Scattering*. Upper Saddle River, NJ, USA: Prentice-Hall, 1991.
- [23] W. C. Chew, *Waves and Fields in Inhomogeneous Media.*, vol. 522. Piscataway, NJ, USA: IEEE Press, 1995.
- [24] N. Tesla, "My inventions," in *Electrical Experimenter* (Parts I–VI), 1919. (Reprint edition with introductory notes by B. Johnson, Barnes and Noble, 1982.)
- [25] G. Marconi, "Transmitting electrical signals, (using Ruhmkorff coil and Morse code key)," U.S. Patent 586 193, Jul. 1897.
- [26] A. Einstein, "On the electrodynamics of moving bodies," *Annalen der Physik*, vol. 17, p. 891, Jan. 1905.
- [27] P. A. M. Dirac, "The quantum theory of the emission and absorption of radiation," *Proc. Roy. Soc. Math. Phys. Eng. Sci.*, vol. 114, no. 767, pp. 243–265, Mar. 1927.
- [28] S. S. Schweber, *QED and The Men Who Made It: Dyson, Feynman, Schwinger, and Tomonaga*. Princeton, NJ, USA: Princeton Univ. Press, 1994.
- [29] L. Mandel and E. Wolf, *Optical Coherence and Quantum Optics*. Cambridge, U.K.: Cambridge Univ. Press, 1995.
- [30] M. O. Scully and M. S. Zubairy, *Quantum Optics*. Cambridge, U.K.: Cambridge Univ. Press, 1997.
- [31] R. Loudon, *The Quantum Theory of Light*. Oxford, U.K.: Oxford Univ. Press, 2000.
- [32] C. Gerry and P. Knight, *Introductory Quantum Optics*. Cambridge, U.K.: Cambridge Univ. Press, 2005.
- [33] M. Fox, *Quantum Optics: An Introduction*, vol. 15, Oxford, U.K.: Oxford Univ. Press, 2006.
- [34] J. Garrison and J. Chiao, *Quantum Optics*. Oxford, U.K.: Oxford Univ. Press, 2014.
- [35] P. W. Milonni, *The Quantum Vacuum: An Introduction to Quantum Electrodynamics*. San Diego, CA, USA: Academic, 1994.
- [36] É. Cartan, *Exterior Differential Systems and Its Applications (in French: Les systemes différentiels extérieurs et leurs applications gomtriques)*. Paris, France: Hermann, 1945.
- [37] K. F. Warnick and P. H. Russer, "Differential forms and electromagnetic field theory," *Prog. Electromagn. Res.*, vol. 148, pp. 83–112, 2014
- [38] C. N. Yang and R. L. Mills, "Conservation of isotopic spin and isotopic gauge invariance," *Phys. Rev.*, vol. 96, no. 1, pp. 191–195, Oct. 1954.
- [39] G. T. Hooft, Ed., *50 Years of Yang-Mills Theory*. Singapore: World Scientific, 2005.
- [40] C. W. Misner, K. S. Thorne, and J. A. Wheeler, *Gravitation*. New York, NY, USA: Macmillan, 1973.
- [41] F. L. Teixeira and W. C. Chew, "Differential forms, metrics, and the reflectionless absorption of electromagnetic waves," *J. Electromagn. Wave*, vol. 13, no. 5, pp. 665–686, 1999.
- [42] R. P. Feynman, *QED: The Strange Story of Light and Matter*. Princeton, NJ, USA: Princeton Science, 1985.
- [43] D. Styer, "Calculation of the anomalous magnetic moment of the electron," 2012. [Online]. Available: <http://www.oberlin.edu/physics/dstyer/StrangeQM/Moment.pdf>
- [44] T. Aoyama, M. Hayakawa, T. Kinoshita, and M. Nio, "Tenth-order QED contribution to the electron g-2 and an improved value of the fine structure constant," *Phys. Rev. Lett.*, vol. 109, no. 11, 2012, Art. no. 111807.
- [45] H. Goldstein, *Classical Mechanics*. Harlow, U.K.: Pearson Educ., 1965.
- [46] K. S. Yee, "Numerical solution of initial boundary value problems involving Maxwell equations in isotropic media," *IEEE Trans. Antennas Propag.*, vol. AP-14, no. 3, pp. 302–307, May 1966.
- [47] A. Taflove and S. C. Hagness, *Computational Electrodynamics*. Norwood, MA, USA: Artech House, 2000.
- [48] A. Messiah, *Quantum Mechanics*, vols. I/II. Mineola, NY, USA: Dover, 1961.
- [49] E. Merzbacher, *Quantum Mechanics*, 3rd ed. New York, NY, USA: Wiley, 1997.
- [50] J. J. Sakurai and J. Napolitano, *Modern Quantum Mechanics*, 2nd ed. New York, NY, USA: Pearson, 2010.
- [51] S. Gasiorowicz, *Quantum Physics*. New York, NY, USA: Wiley, 1997.
- [52] K. Gottfried and T. M. Yan, *Quantum Mechanics: Fundamentals*. New York, NY, USA: Springer, 2013.
- [53] P. A. M. Dirac, *The Principles of Quantum Mechanics*. Oxford, U.K.: Oxford Univ. Press, 1981.
- [54] R. P. Feynman, R. Leighton, and M. Sands, *The Feynman Lectures on Physics*, vol. 3. Boston, MA, USA: Addison-Wesley Longman, 1970.
- [55] W. C. Chew, *Quantum mechanics made simple, UIUC ECE 487 lecture notes*, 2015. [Online]. Available: <http://wcchew.ece.illinois.edu/chew/course/QMail20150602.pdf>
- [56] E. Schrödinger, "An undulatory theory of the mechanics of atoms and molecules," *Phys. Rev.*, vol. 28, no. 6, pp. 1049–1070, Dec. 1926.
- [57] L. de Broglie, "Researches on the quantum theory," *Ann. Phys.*, vol. 10, no. 3, p. 22, 1925.
- [58] M. Planck, *The Theory of Heat Radiation* (Transl.: M. P. Masius). Philadelphia, PA, USA: Blakiston's Sons, 1914.
- [59] A. Einstein, "On a heuristic point of view about the creation and conversion of light," *Ann. Phys.*, vol. 17, no. 6, pp. 132–148, 1905.
- [60] H. R. Hertz, "On an effect of ultra-violet light upon the electrical discharge," *Ann. Phys.*, vol. 267, no. 8, pp. 983–1000, 1887.
- [61] M. H. Devoret, "Quantum fluctuations in electrical circuits," in *Fluctuations Quantiques/Quantum Fluctuations: Les Houches Session LXIII*, S. Reynaud, E. Giacobino, and J. Zinn-Justin, Ed. Amsterdam, The Netherlands: Elsevier, 1997.
- [62] H. Haken, *Quantum Field Theory of Solids, an Introduction*. Amsterdam, The Netherlands: Elsevier, 1983.
- [63] C. F. Stevens, *The Six Core Theories of Modern Physics*. Boston, MA, USA: MIT Press, 1956.
- [64] W. C. Chew, "Vector potential electromagnetics with generalized gauge for inhomogeneous media: Formulation," *Prog. Electromagn. Res.*, vol. 149, pp. 69–84, 2014.

W. C. Chew, photograph and biography not available at the time of publication.

A. Y. Liu, photograph and biography not available at the time of publication.

C. Salazar-Lazaro, photograph and biography not available at the time of publication.

W. E. I. Sha, photograph and biography not available at the time of publication.